

IMPORTANT WARNING:

DO NOT EXCEED MAXIMUM
TOTAL WEIGHT LIMIT OF
120 LBS

MAX LOAD Per Hook
25 LBS

MAX WEIGHT Per Bike
50 LBS

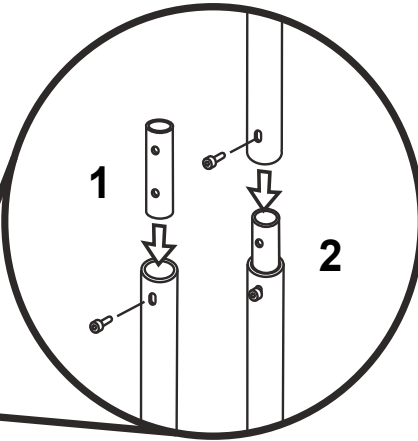
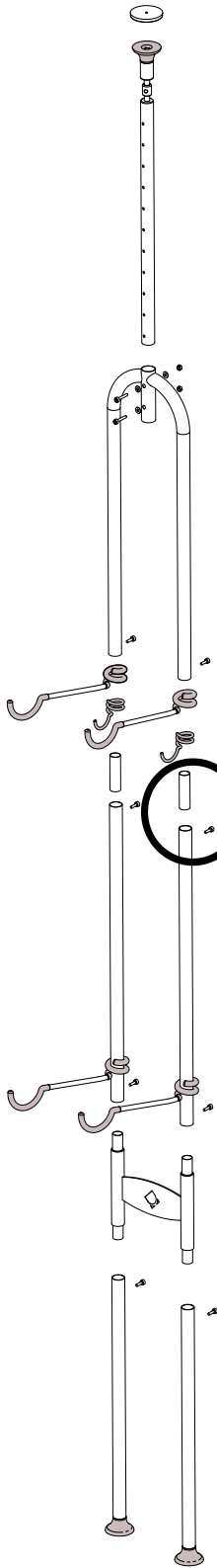

ASSEMBLY TIPS

1. Position rubberized arms on legs before attaching bolts.
2. Wait until all parts of rack are assembled before fully tightening bolts.

To order an extra set of support arms to hold more bikes, visit www.theartofstorage.com.

Part # RS6400

Kit includes 2 large arms and 2 small arms.

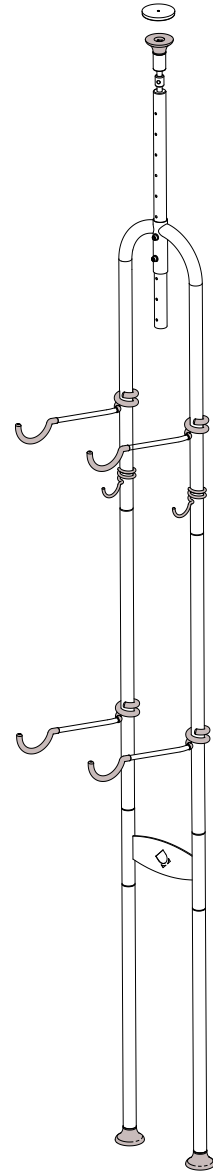
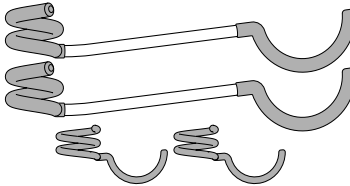

SEE REVERSE SIDE FOR ASSEMBLY PROCEDURE



theartofstorage™

Delta Design Company
21 Cocasset Street
Foxborough, MA 02035 USA

CHAGALL RS7750
ASSEMBLY DIAGRAM

© Copyright 2007

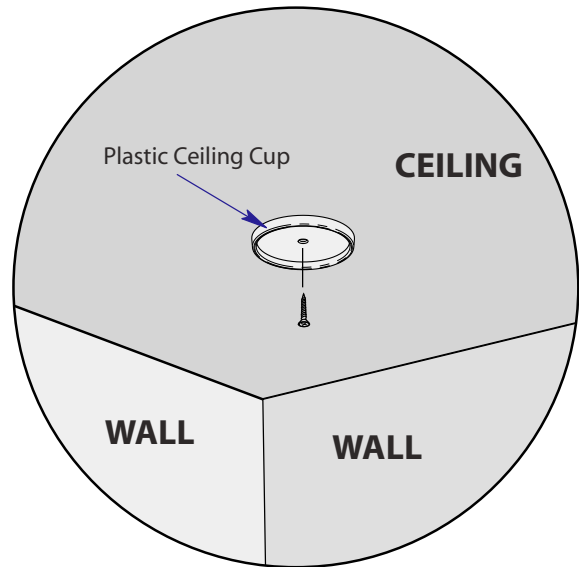
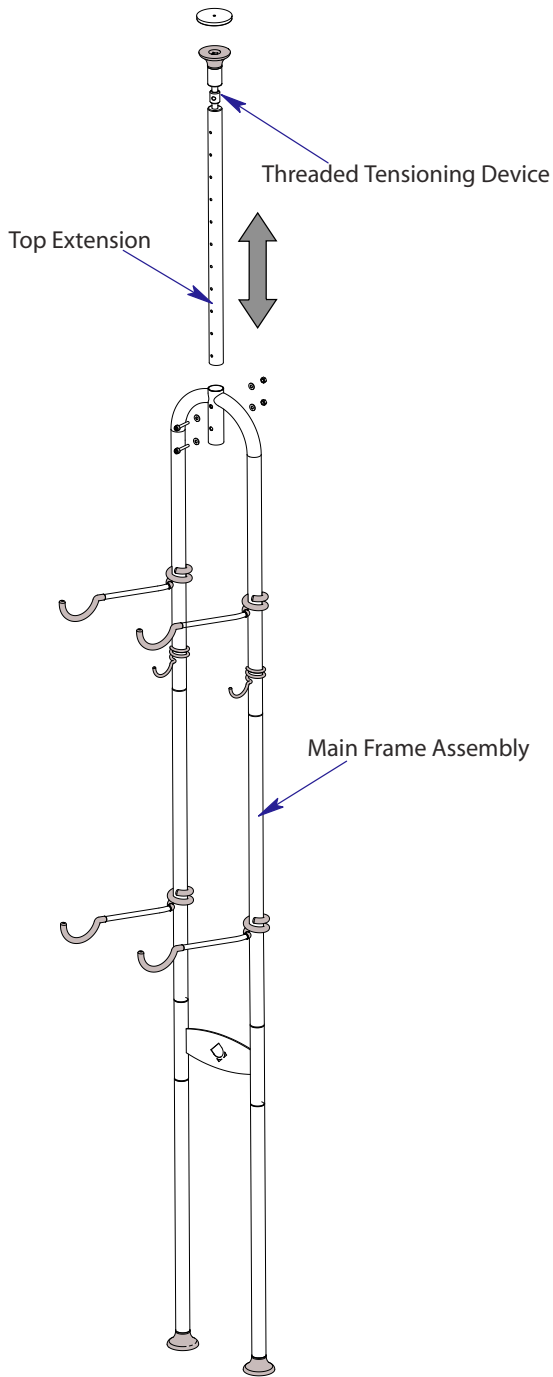

4. Mark ceiling directly over where rack will be placed.
5. Screw plastic ceiling cup in place using suitable fixing screw. (if in doubt about this attachment, consult an expert or your local hardware store before proceeding)

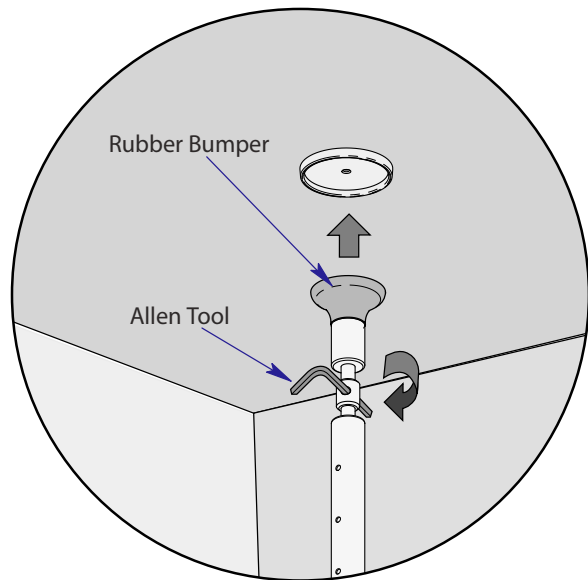

6. While holding rubber bumper, insert allen tool and screw threaded section to extend rack into plastic ceiling cup until rack is firmly in position.

CAUTION: Check at regular intervals to ensure tension is maintained and rack is secured in place. Overtightening could cause damage to ceiling.

1. Assemble main frame of rack as shown on opposite page.
2. Measure distance between your floor and ceiling. (should be between 7'6" and 9'6" to accept rack)
3. Determine best position of top extension (should be 1/2" - 2" shorter than height of ceiling) and attach main frame assembly with supplied hardware.



the art of storage™

Delta Design Company
21 Cocasset Street
Foxborough, MA 02035 USA

CHAGALL RS7750
ASSEMBLY DIAGRAM

© Copyright 2007