

theartofstorage™

Delta Design Company
 125 Washington St. Unit #7
 Foxborough, MA 02035 USA
 Phone: 800-474-6615

BRAQUE RS7300
 Exploded Part Diagram

© Copyright 2008

SEE REVERSE SIDE ↩

Assemble from the
Bottom to Top

1

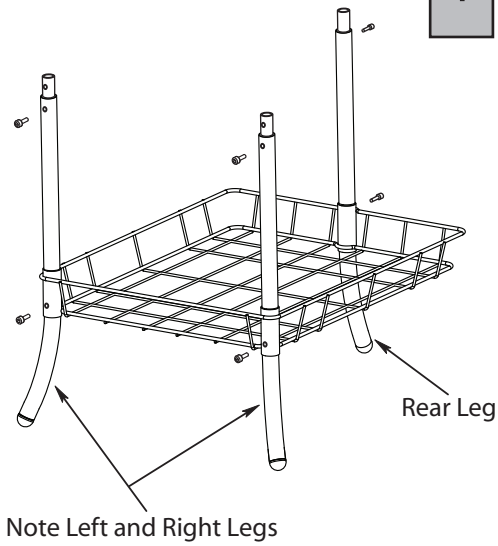

Slide shelves, O rings, and hooks (both sizes!)
onto tubes before attaching bolts

2

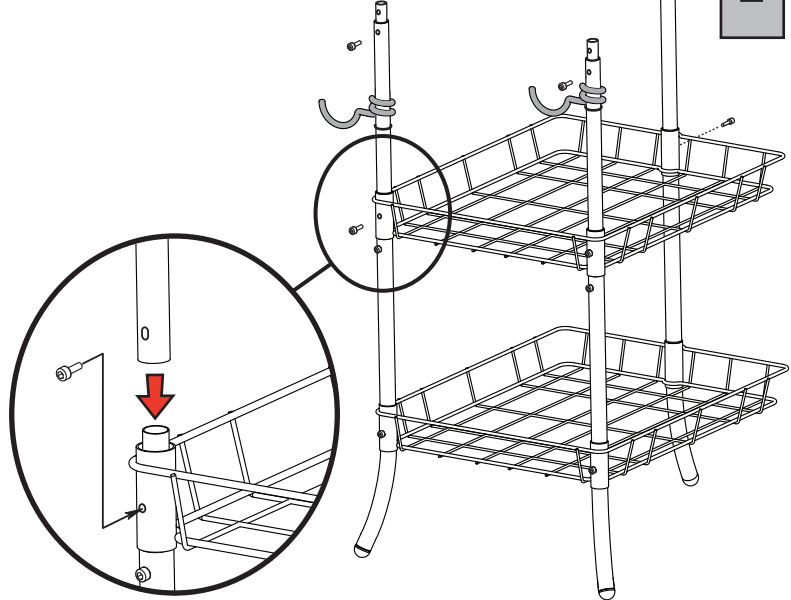

3

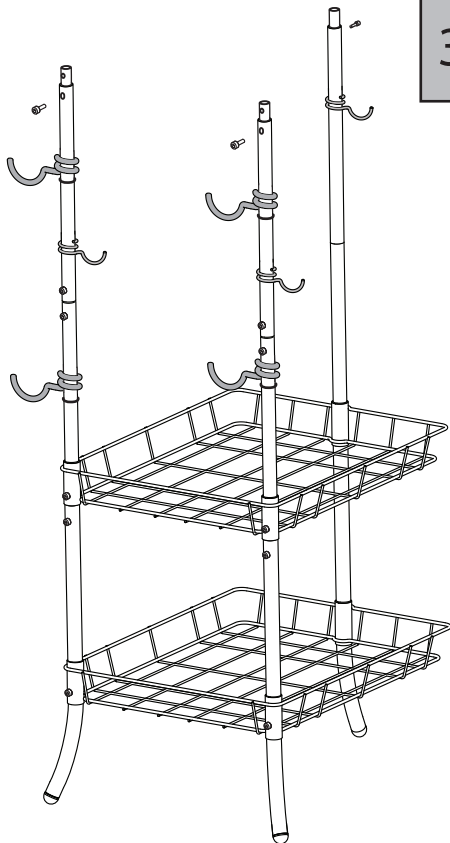

4

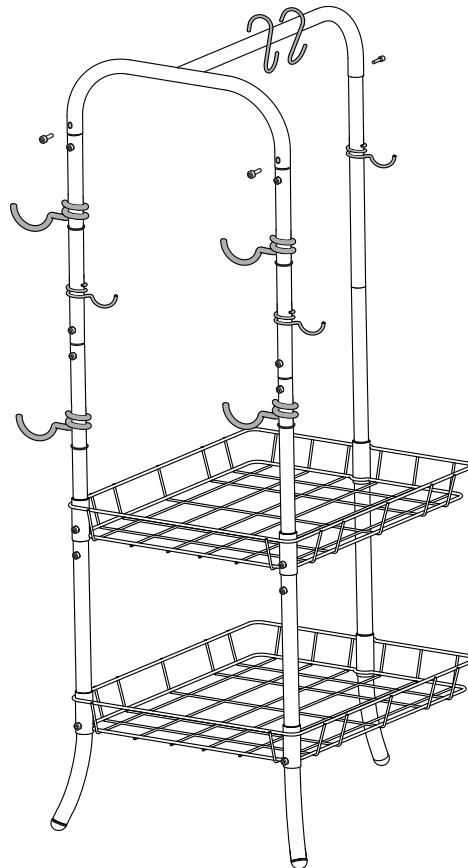

SAFETY WARNING: Distribute weight evenly on rack to avoid possibility of rack and contents tipping over and causing injury. Avoid protruding hooks where they could cause injury if accidentally walked into. Do not climb or allow children to play on this rack.



theartofstorage™

Delta Design Company
125 Washington St. Unit #7
Foxborough, MA 02035 USA
Phone: 800-474-6615

BRAQUE RS7300
ASSEMBLY DIAGRAM

© Copyright 2008

MAKE LIFE EASY: SEE REVERSE SIDE FOR ASSEMBLY PROCEDURE ↷

CUSTOMER SERVICE : 1-800-474-6615

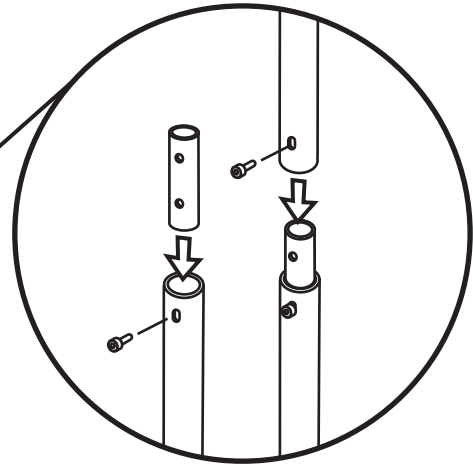
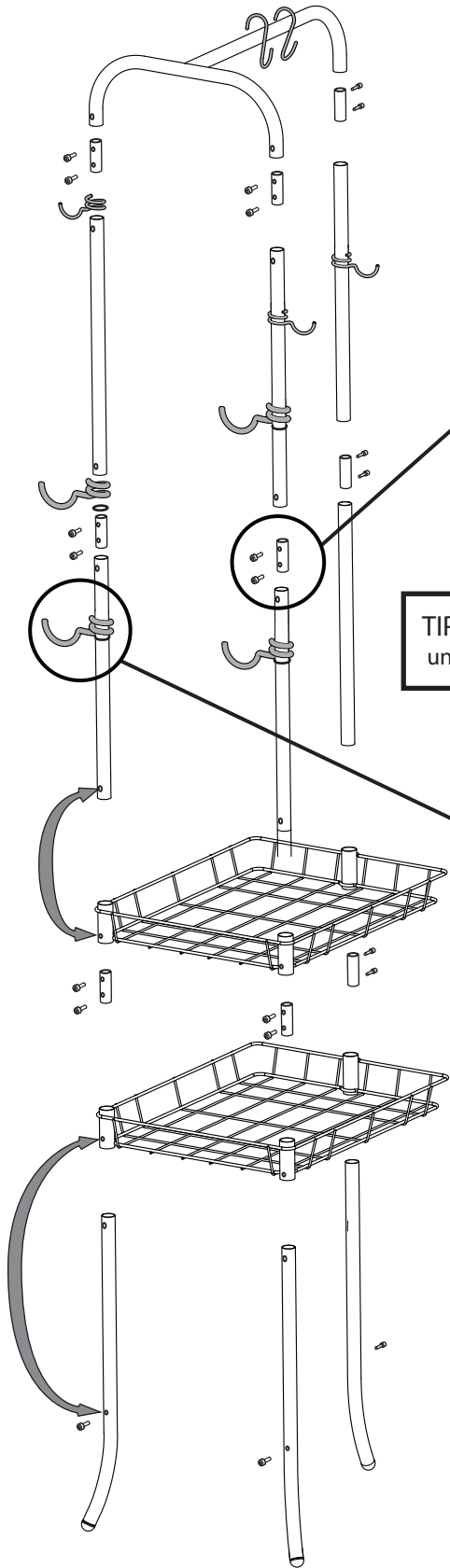

TIP: Wait to fully tighten bolts, until all parts of rack are assembled.

IMPORTANT WARNING:
DO NOT EXCEED MAXIMUM TOTAL WEIGHT LIMIT OF 210 LBS
MAX LOAD Per Large Hook 25 LBS
MAX LOAD Per Small Hook 10 LBS
MAX WEIGHT Per Shelf 40 LBS
MAX WEIGHT Per Bike 40 LBS

O Rings Keep the arms in correct position. Make sure that the O Rings are placed on the rack frame before assembly.

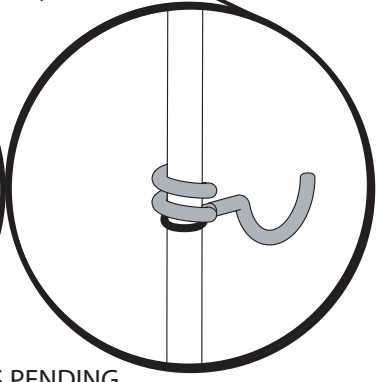
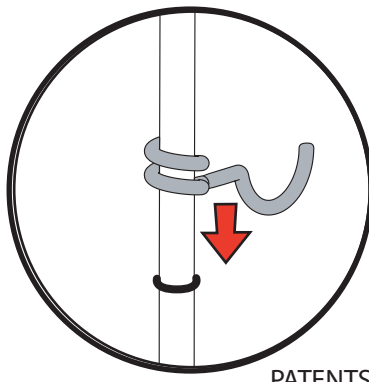

PATENTS PENDING
© Copyright 2008



theartofstorage™

Delta Design Company
125 Washington St. Unit #7
Foxborough, MA 02035 USA
Phone: 800-474-6615

BRAQUE RS7300
ASSEMBLY DIAGRAM

© Copyright 2008